

Corning® LSE™ Platform Rockers

CORNING

Instruction Manual

Catalog Numbers:

6703
6704
6705
6706



UK
CA CE

Table of Contents

- 1.0 General Specifications 1
- 2.0 Safety Precautions..... 1
- 3.0 Installation of the Platform Rocker 2
 - 3.1 Unpacking..... 2
 - 3.2 Selecting the Location..... 2
 - 3.3 Adjusting the Angle..... 3
 - 3.4 Attaching the Power Cord 3
 - 3.5 Installing Double Stacking Platform..... 3
- 4.0 Operating Instructions..... 4
 - 4.1 Controls 4
 - 4.2 Basic Operation..... 4
- 5.0 Troubleshooting Guide 4
- 6.0 Maintenance and Cleaning 5
- 7.0 Limited Warranty..... 5
- 8.0 Equipment Disposal 6

1.0 General Specifications

Speed Settings	5 to 120 tilts/minute
Timer	0 to 2 hours or continuous
Motion	Rocking
Tilt Angle	Fixed 7°
Maximum Load	11 lbs. (5 kg)
Ambient Operation Range	+4°C to 65°C, up to 85% RH, non-condensing
Dimensions	12.8 x 14.2 x 5.7 in. (32.5 x 36 x 14.5 cm)
Weight	11.7 lbs. (5.3 kg)
Electrical	
120V	120V ± 10%, 50/60Hz, 0.3A
230V	230V ± 10%, 50/60Hz, 0.15A
Fuse	2 x 1A
Warranty	5 years
Platform Size	11.8 x 11.8 in. (30 x 30 cm)

This device is intended for use in a basic electromagnetic environment (Basic, class B), and it is in compliance with IEC 61326-1.

The Corning® LSE™ Platform Rocker is designed to be safe when operated under the following conditions:

- ▶ Indoor use
- ▶ Altitude up to 2,000 meters
- ▶ Pollution Degree 2

2.0 Safety Precautions



Do not use the rocker near water. Ensure that water does not get on the device, particularly during cleaning.

- ▶ If the unit is used in a manner not specified in this manual, then the unit may become unsafe to operate and may void the warranty.
- ▶ This product must be connected to a grounded power outlet for safe functioning.
- ▶ Use only the power cord supplied with the product.
- ▶ The equipment will not restart if the main power source is interrupted.
- ▶ The equipment will restart in cases of mechanical interruption.
- ▶ Do not expose the rocker to aggressive vapors (e.g., organic solvents).
- ▶ Do not insert any objects into the rocker (such as a screwdriver or metal rods).
- ▶ Never operate the rocker without the platform securely attached.
- ▶ Hazardous samples should be shaken only in appropriate containment vessels.



Do not rock flammable or explosive samples.



The electrical warning symbol indicates the presence of a potential hazard which could result in electrical shock.



Do not put your fingers between the rocking platform and the housing. Danger of mechanical injury.

3.0 Installation of the Platform Rocker

3.1 Unpacking

Before starting the installation, carefully examine the rocker for possible damage or missing parts.

- ▶ Open the box and carefully remove the padding. Check that the rocker has not been visibly damaged during transportation. Keep the packing material until you ensure that the rocker works properly.
- ▶ Carefully lift the device out of the box.
- ▶ Be sure that the following information is included on the serial label located on the back of the unit: serial number, catalog number, electrical rating.
- ▶ Check that the power cord plug has a pin configuration that matches a wall socket according to the local standard.

Should any kind of damage have occurred during transportation, contact the carrier immediately. The carrier is responsible for shipping damage.

3.2 Selecting the Location

- ▶ Put the rocker on a horizontal, leveled, and stable surface.
- ▶ Leave enough space around the rocker for normal air circulation (6 in./15 cm minimum).
- ▶ Leave enough space around the rocker for easy access and maintenance.
- ▶ Avoid locations subject to shocks and vibrations.
- ▶ Avoid locations subject to frequent power fluctuations or power losses, as this may affect rocker performance.

Select a location that is dry and not subject to drafts or moving air from heating or air conditioning vents or air blown by other equipment. Plug the unit into a properly grounded outlet.

3.3 Adjusting the Angle

Unload the platform. Locate the knob on the right hand side of the rocker. Note the tilt degree markings on the platform drive rod (front center under platform). Loosen knob on the side by rotating counterclockwise. Adjust the platform to desired tilt angle. Retighten the knob on the side by turning clockwise. Test the unit without load to ensure platform is tight.

NOTE: You may need to turn the rocker on and off to change drive rod position before adjusting.

3.4 Attaching the Power Cord

Connect the main power cord to the rocker and then connect the plug end of the cord to a grounded wall socket. Avoid lines to which powerful electric motors, refrigerators, and similar devices are connected.



Be careful when you plug the cord to a grounded wall socket. Do not touch plug with wet hands. Do not pull the plug by the cord.

3.5 Installing Double Stacking Platform

1. Set the posts (A) through the 4 holes at the corners of the bottom platform.
2. Add a washer (B) and nut (C) to each post.
3. Fit the upper platform (D) on the top of the 4 posts through the corner holes.
4. Screw on the 4 metal knurl nuts (E) to secure the upper platform.

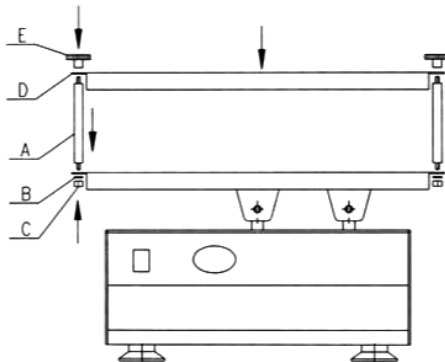

NOTE: Misuse or unauthorized modifications will waive the warranty rights. If the equipment is used in a manner not specified by the manufacturer, the safety features of the rocker may be impaired.

4.0 Operating Instructions

4.1 Controls



- 1. POWER switch:** Turns the rocker ON (power switch illuminates) or OFF
- 2. SPEED knob:** Sets the rocker speed
- 3. TIME knob:** Sets the time of the rocker
- 4. HOLD yellow light:** Illuminates when the rocker is set for continuous running
- 5. START/STOP button:** START or STOP rocking
- 6. RUN green light:** Illuminates when the rocker is running

4.2 Basic Operation

- ▶ Switch on POWER.
- ▶ Set SPEED knob on desired value.
- ▶ Set TIME knob on desired value or on HOLD – continuous function (yellow light next to HOLD will illuminate).
- ▶ Press START/STOP button to start rocking.
- ▶ Press START/STOP button to stop rocking (HOLD position). Device automatically stops after the set time passes. Note: Pressing the START/STOP button during operation will reset the timer.

5.0 Troubleshooting Guide

Be sure to disconnect the rocker from the main power source immediately in case of any signs of malfunction and contact Corning Customer Service at 800.492.1110 or 978.442.2200.

Problem	Solution
Power switch does not light up	Check the power connection. Check the fuses. Contact Corning Customer Service.
Rocker does not start	Check the power connection. Check the fuses. Contact Corning Customer Service.

6.0 Maintenance and Cleaning

- ▶ No routine maintenance or lubrication is required.
- ▶ It is recommended that the rocker be kept clean to ensure a long, trouble-free operation.

The outside housing of the platform rocker may be cleaned with a soft, damp cloth when needed. Do not use any aggressive or abrasive cleaners (acetone, nitro, polish, etc.), as they may permanently damage the rocker finish.



Before cleaning the rocker, always unplug the power cord from the wall socket. Make sure the rocker is switched off before installing an additional platform.

7.0 Limited Warranty

Corning Incorporated (Corning) warrants that this product will be free from defects in material and workmanship for a period of five (5) years from date of purchase. CORNING DISCLAIMS ALL OTHER WARRANTIES WHETHER EXPRESSED OR IMPLIED, INCLUDING ANY IMPLIED WARRANTIES OF MERCHANTABILITY OR OF FITNESS FOR A PARTICULAR PURPOSE. Corning's sole obligation shall be to repair or replace, at its option, any product or part thereof that proves defective in material or workmanship within the warranty period, provided the purchaser notifies Corning of any such defect. Corning is not liable for any incidental or consequential damages, commercial loss, or any other damages from the use of this product.

This warranty is valid only if the product is used for its intended purpose and within the guidelines specified in the supplied instruction manual. This warranty does not cover damage caused by accident, neglect, misuse, improper service, natural forces, or other causes not arising from defects in original material or workmanship. This warranty does not cover motor brushes, fuses, light bulbs, batteries, or damage to paint or finish. Claims for transit damage should be filed with the transportation carrier.

In the event this product fails within the specified period of time because of a defect in material or workmanship, contact Corning's Customer Service at 800.492.1110. Outside the United States, call +1.978.442.2200 or contact your local Corning sales office.

Corning Customer Service will help arrange local service where available or coordinate a return authorization number and shipping instructions. Products received without proper authorization will be returned. All items returned for service should be sent postage prepaid in the original packaging or other suitable carton, padded to avoid damage. Corning will not be responsible for damage incurred by improper packaging. Corning may elect for onsite service for larger equipment.

Some states do not allow limitation on the length of implied warranties or the exclusion or limitation of incidental or consequential damages. This warranty gives you specific legal rights. You may have other rights which vary from state to state.

No individual may accept for, or on behalf of Corning, any other obligation of liability, or extend the period of this warranty.

For your reference, make a note of the serial and model number, date of purchase, and supplier here.

Model No. _____ Serial No. _____

Date Purchased _____ Supplier _____

8.0 Equipment Disposal



According to Directive 2012/19/EU of the European Parliament and Council of 4th July 2012 on waste and electronic equipment (WEEE) as amended, the Corning® LSE™ Platform Rockers are marked with the crossed-out wheeled bin and must not be disposed of with domestic waste.

Consequently, the buyer shall follow the instructions for reuse and recycling of waste electronic and electrical equipment (WEEE) provided with the products and available at www.corning.com/weee.

Warranty/Disclaimer: Unless otherwise specified, all products are for research use or general laboratory use only.* Not intended for use in diagnostic or therapeutic procedures. Not for use in humans. These products are not intended to mitigate the presence of microorganisms on surfaces or in the environment, where such organisms can be deleterious to humans or the environment. Corning Life Sciences makes no claims regarding the performance of these products for clinical or diagnostic applications. *For a listing of US medical devices, regulatory classifications or specific information on claims, visit www.corning.com/resources.

CORNING

Corning Incorporated
Life Sciences

www.corning.com/lifesciences

NORTH AMERICA

t 800.492.1110
t 978.442.2200

ASIA/PACIFIC

Australia/New Zealand
t 61 427286832

Chinese Mainland
t 86 21 3338 4338

India
t 91 124 4604000

Japan
t 81 3-3586 1996

Korea
t 82 2-796-9500

Singapore
t 65 6572-9740

Taiwan
t 886 2-2716-0338

EUROPE

CSEurope@corning.com

France
t 0800 916 882

Germany
t 0800 101 1153

The Netherlands
t 020 655 79 28

United Kingdom
t 0800 376 8660

All Other European Countries
t +31 (0) 206 59 60 51

LATIN AMERICA
grupoLA@corning.com

Brazil
t 55 (11) 3089-7400

Mexico
t (52-81) 8158-8400